

PRODUCT SPECIFICATION

CDTECH Model: **S150HWU03FP-FC01**

CUSTOMER Model: **-**

Description: **15.0 ” TFT-LCD Module with CTP**

Version: **1.0**

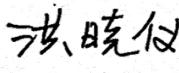
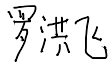
CDTECH	PREPARED BY	CHECKED BY	APPROVED BY
SIGNATURE			
DATE	2026.4.13	2026.4.13	2026.4.13

CUSTOMER APPROVAL	SIGNATURE	DATE



Contents

1. General Specifications	4
2. Absolute Maximum Ratings	5
3. Electrical Characteristics	5
4. Interface Pin Assignment	7
5. Interface Characteristics	9
6. Optical Specifications	9
7. Reliability Test Items	23
8. Mechanical Drawing	24
9. Packing	25
10. Precautions for Use of LCD modules	26

1. General Specifications

1.1 LCM General Information

Item	Specification	Unit
LCD Size	15.0	inch
Number of Pixels	1920 (H) RGB x 720 (V)	pixels
Display Mode	Normally Black	-
Viewing Direction	Free	-
Interface	LVDS	-
Display Colors	16.7M	colors
Outline Dimension	446.8 (H) x 196.0 (V) x 11.65 (D)	mm
Active Area	355.68 (H) x 133.38 (V)	mm
Pixel Pitch	0.1852 (H) x 0.1852 (V)	mm
Driver IC	HX82102	-
Operation Temperature	-30~85	°C
Storage Temperature	-30~85	°C

1.2 Touch Panel Information

Item	Specification
Touch Structure	G+G
Bonding Type with LCM	OCA Optical Bonding
Driver IC	ILI2511
Interface	I ² C&USB
Touch Count Max	5 Points
Surface treatment	-
Surface hardness	6H
I2C slave address	0x82
Origin of coordinate	Top Left Corner

Note 1: Requirements on environmental protection RoHS compliant.

2. Absolute Maximum Ratings

Item	Symbol	MIN.	MAX.	Unit	Note
Analog Supply voltage	VDD	-0.3	4.0	V	Note 1

Note 1: Permanent damage may occur to the LCD module if beyond this specification.

Functional operation should be restricted to the conditions described under normal operating conditions.

3. Electrical Characteristics

3.1 Recommended Operating Condition for TFT LCD

Item	Symbol	Min.	Typ.	Max.	Unit	Note
Analog Supply voltage	VDD	3.0	3.3	3.6	V	
Analog supply current	I_{VDD}	-	420	550	mA	VDD=3.3V (RED)
Logic input voltage	V _{IH}	0.7*VDD	-	VDD	V	
	V _{IL}	GND	-	0.3*VDD	V	

3.2 Recommended Driving Condition for Backlight

Item	Symbol	Min.	Typ.	Max.	Unit	Note
Driving Current	I_F	-	460	-	mA	
Driving Voltage	V_F	21.6	-	27.2	V	
Power consumption	W_{BL}	9.936	-	12.512	W	
LED Life-Time	N/A	-	50,000	-	Hours	Ta=25°C Note 1

Note 1: LED lifetime is defined as the module brightness decay 50% of original brightness at Ta=25 degree, typical current.

Note 2:LED circuit :

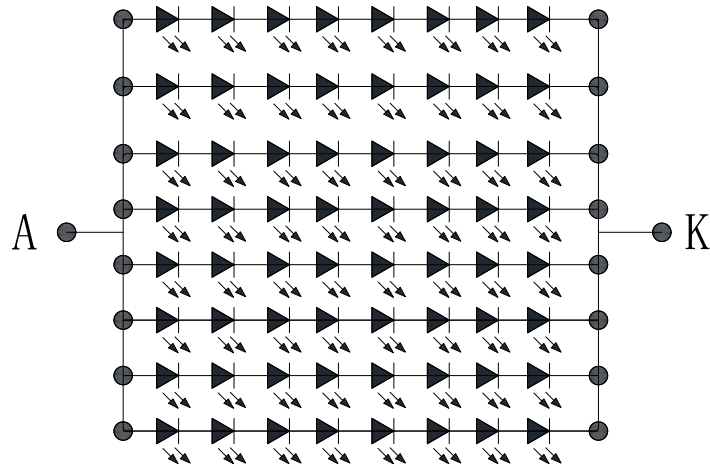

3.3 Touch Panel

Item	Symbol	Min.	Typ.	Max.	Unit	Note
Power Supply voltage	CTP_VDD	-	3.3	-	V	
Analog supply current	I_{CTP_VDD}	-	100	-	mA	CTP_VDD=3.3V
Input high-level voltage	V_{IH}	$0.7 \cdot CTP_VDD$	-	CTP_VDD	V	
Input low -level voltage	V_{IL}	GND	-	$0.3 \cdot CTP_VDD$	V	

4. Interface Pin Assignment

4.1 LCM Pin Assignment

No.	Symbol	Description
1	NC	No connection
2-3	GND	Ground
4	CSB(NC)	No connection
5	SCL(NC)	No connection
6	SDA(NC)	No connection
7	RESET	Global reset pin
8	STBYB	STBYB = L, timing controller, source driver will turn off STBYB = H, normal operation (Default)
9-10	VDD	supply voltage
11-12	GND	Ground
13	OLVD3P	+ LVDS differential data input
14	OLVD3N	- LVDS differential data input
15	GND	Ground
16	OLVD2P	+ LVDS differential data input
17	OLVD2N	- LVDS differential data input
18	GND	Ground
19	OLVDCLKP	+ CLKP differential clock input
20	OLVDCLKN	- CLKN differential clock input
21	GND	Ground
22	OLVD1P	+ LVDS differential data input
23	OLVD1N	- LVDS differential data input
24	GND	Ground
25	OLVD0P	+ LVDS differential data input
26	OLVD0N	- LVDS differential data input
27-28	GND	Ground
29	FAIL_DET(NC)	No connection
30-31	VDD	supply voltage
32	ATREN(NC)	No connection
33	VDD_OTP(NC)	No connection
34	NC	No connection
35-36	GND	Ground
37	NC	No connection
38	NC	No connection
39	NC	No connection

40	NC	No connection
41	LEDA1(NC)	No connection
42	LEDA2(NC)	No connection
43	LEDA3(NC)	No connection
44	LEDA4(NC)	No connection
45	NC	No connection
46	LEDK1(NC)	No connection
47	LEDK2(NC)	No connection
48	LEDK3(NC)	No connection
49	LEDK4(NC)	No connection
50	NC	No connection

4.2 Touch FPC Pin Assignment

No.	Symbol	Description
1	CTP_VDD_3V3	Power supply for CTP (3.3V)
2	I2C_SCL_CTP	I2C clock input for CTP
3	I2C_SDA_CTP	I2C data input and output for CTP
4	I2C_RESET_CTP	Reset Pin for CTP
5	I2C_INT_CTP	Interrupt signal for CTP
6	CTP_GND	Ground
7	CTP_GND	Ground
8	CTP_USB_D+	Data+ input
9	CTP_USB_D-	Data- input
10	CTP_VDD_5V0	Power supply for CTP (5.0V)

4.3 BLS Pin Assignment

No.	Symbol	Description
1	LEDA	Power for LED backlight (Anode)
2	LEDA	Power for LED backlight (Anode)
3	LEDA	Power for LED backlight (Anode)
4	NC	No connection
5	LEDK	Power for LED backlight (Cathode)
6	LEDK	Power for LED backlight (Cathode)
7	LEDK	Power for LED backlight (Cathode)
8	LEDK	Power for LED backlight (Cathode)
9	NTC_1	Thermistor pin1
10	NTC_2	Thermistor pin2

5. Interface Characteristics

5.1 Power Sequence

E. VSP=VSDP and VSN=VSDN by external power supply, and VGH and VGL by external power supply (PWR_SPEED=1)

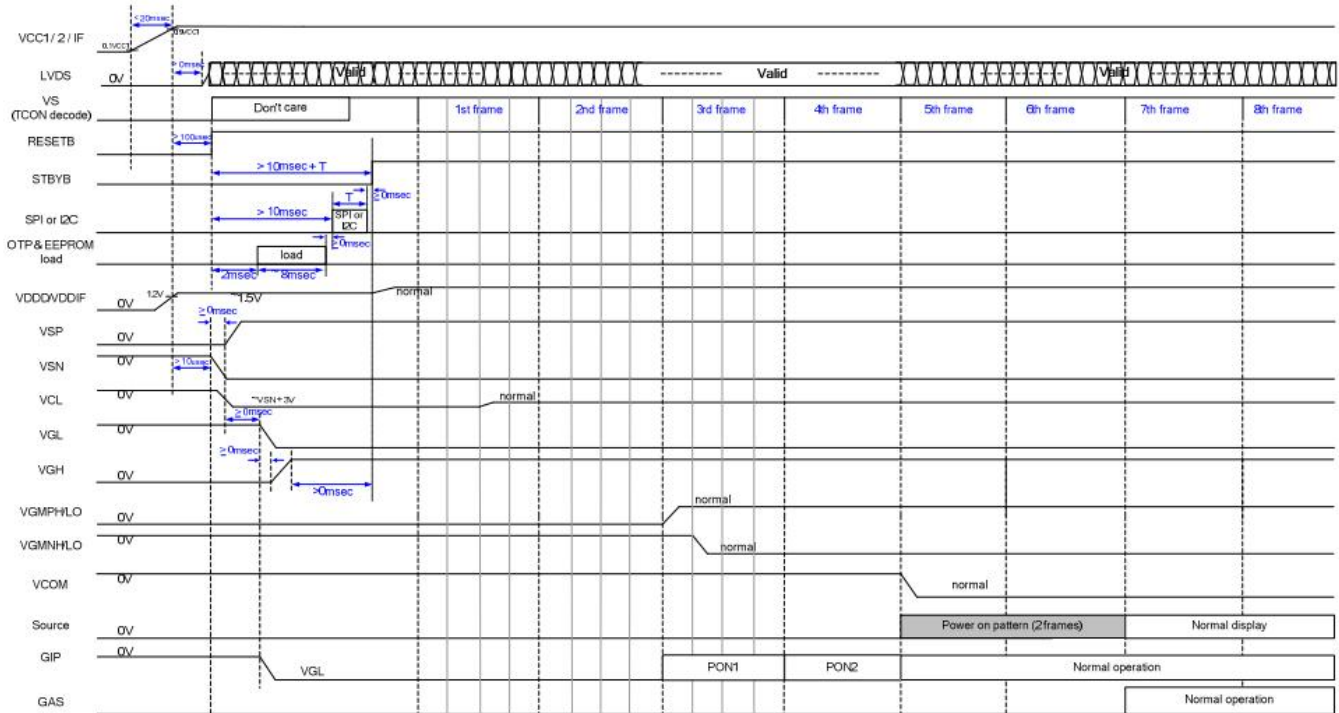

Figure 6-17: Power-on sequence with external VSP/VSN/VGH/VGL (PWR_SPEED=1)

C. If VSP=VSDP and VSN=VSDN by external power supply, and VGH and VGL generated by external power supply:

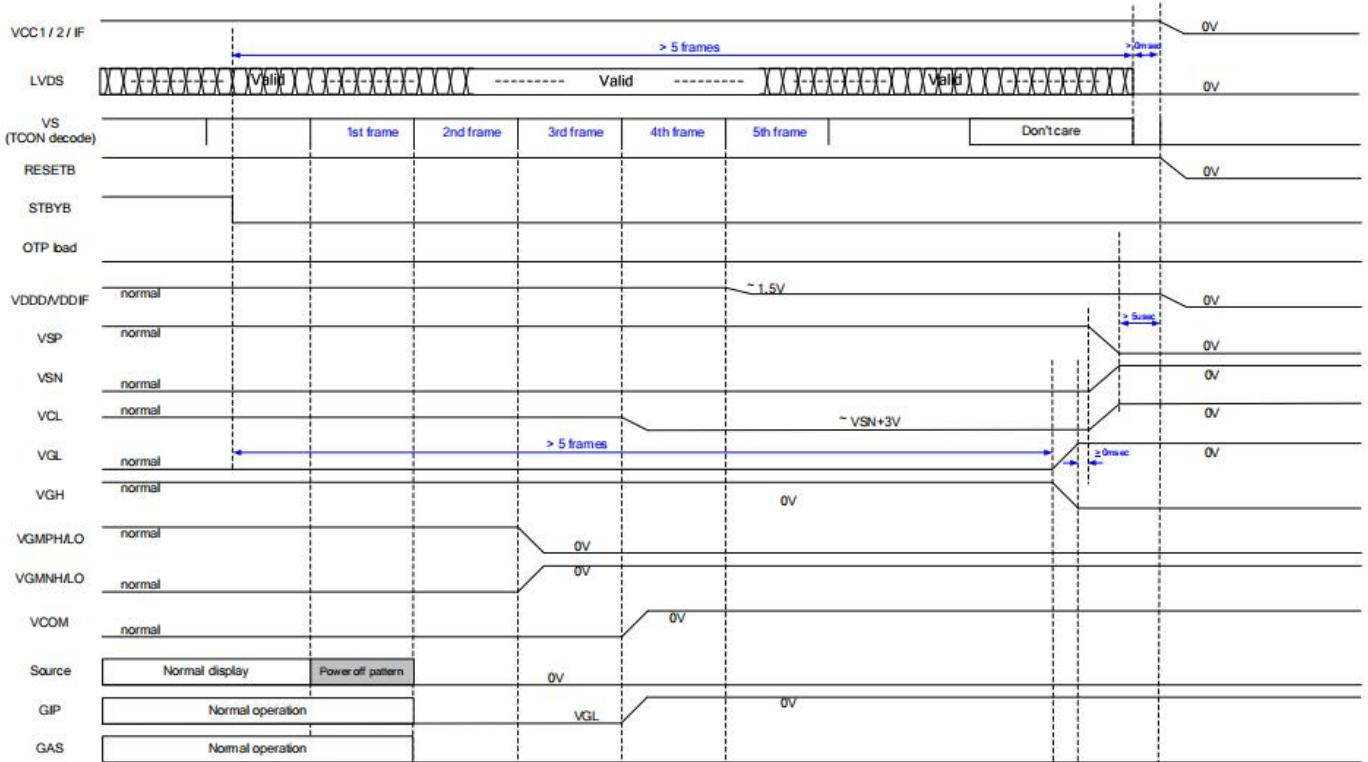

Figure 6-21: Power-off sequence with external VSP/VSN/VGH/VGL

5.2 DC Characteristics

For the digital circuit: LVDS mode

Parameter	Symbol	Condition	Spec.			Unit
			Min.	Typ.	Max.	
Differential input high Threshold voltage	Vth	Vcm=1.2V	+0.10	-	-	V
Differential input low threshold voltage	Vtl	Vcm=1.2V	-	-	-0.10	V
Differential input common Mode voltage	VCM	-	1	1.2	1.7- Vid /2	V
LVDS input voltage	VINLV	-	0.7	-	1.7	V
Differential input voltage	Vid	-	0.1	-	0.6	V
Differential input leakage Current	Ilvleak	-	-10	-	+10	μA

Table 9.1: LVDS mode DC electrical characteristics

Single-ended:
LVCLKP,
LVCLKN,
LVD[3:0]P,
LVD[3:0]N

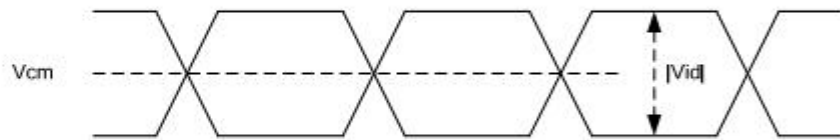

Differential:
LVCLKP-LVCLKN,
LVD[: - :

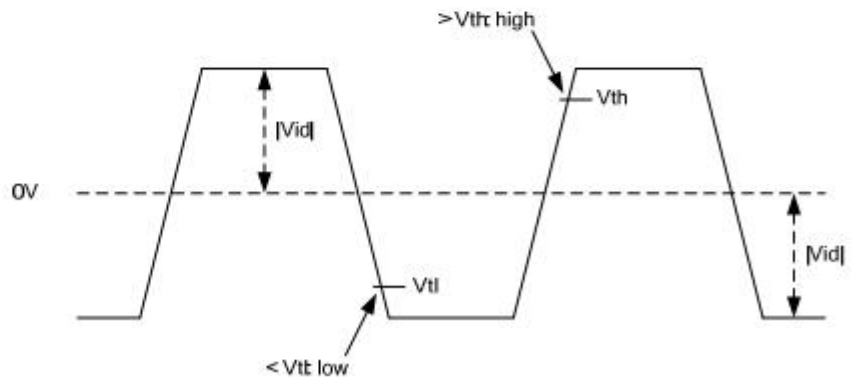

Figure 9-1: LVDS mode DC electrical characteristics

5.3 AC Characteristics

LVDS mode AC electrical characteristics

Parameter	Symbol	Spec.			Unit
		Min.	Typ.	Max.	
Clock frequency (1-port/2-port)	F_{LVCCYC}	15	-	110/105	MHz
Clock period (1-port/2-port)	T_{LVCCYC}	9.09/9.52	-	-	ns
1 data bit time	UI	-	1/7	-	T_{LVCCYC}
Clock high time	T_{LVCH}	-	4	-	UI
Clock low time	T_{LVCL}	-	3	-	UI
Position 1	T_{POS1}	-0.2	0	0.2	UI
Position 0	T_{POS0}	0.8	1	1.2	UI
Position 6	T_{POS6}	1.8	2	2.2	UI
Position 5	T_{POS5}	2.8	3	3.2	UI
Position 4	T_{POS4}	3.8	4	4.2	UI
Position 3	T_{POS3}	4.8	5	5.2	UI
Position 2	T_{POS2}	5.8	6	6.2	UI
Input eye width	T_{EYEW}	0.6	-	-	UI
Input eye border	T_{EX}	-	-	0.2	UI
LVDS wake up time	T_{ENLVDS}	-	-	150	us
LVDS port to port skew	T_{skew_EO}	-1		1	UI

Table 9.2: LVDS mode AC electrical characteristics

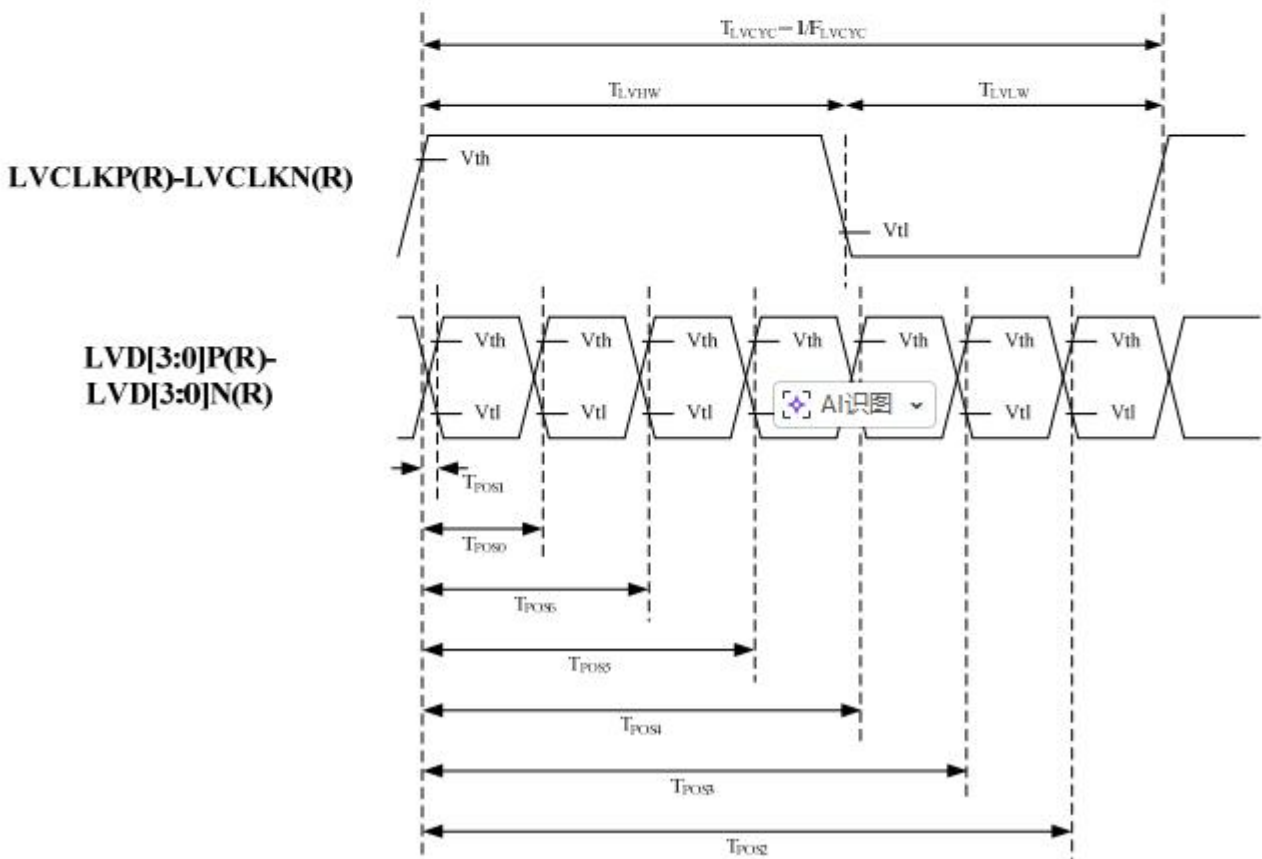
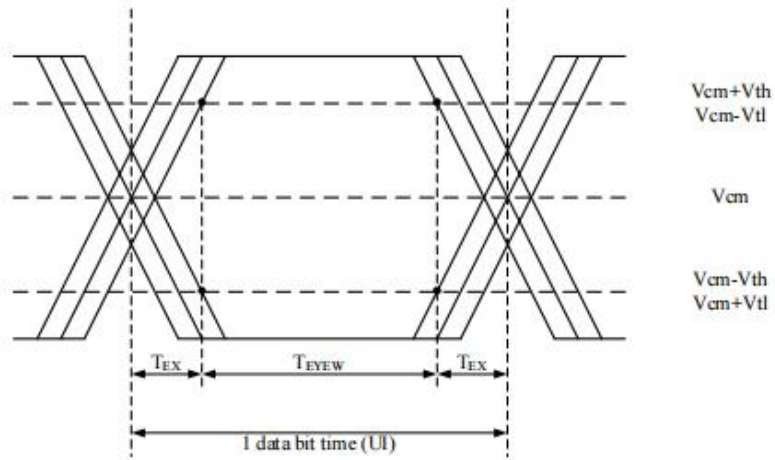

Figure 9-2: LVDS input timing

Single-ended:
LVD[3:0]P,
LVD[3:0]N



Differential:
LVD[3:0]P-LVD[3:0]N

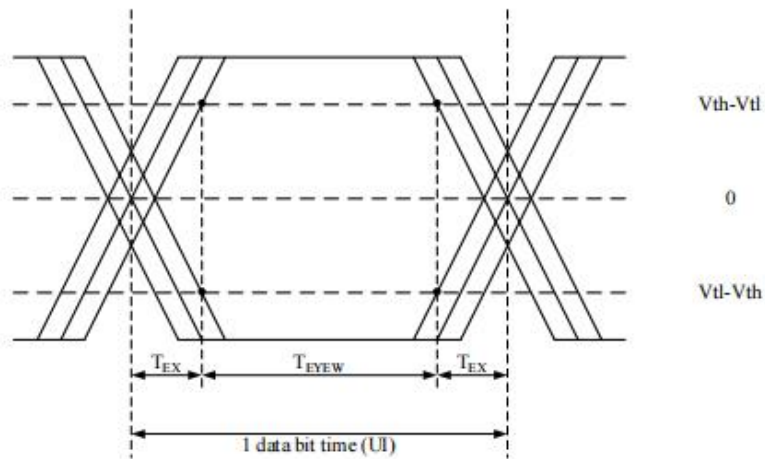

Figure 9-3: LVDS input eye diagram

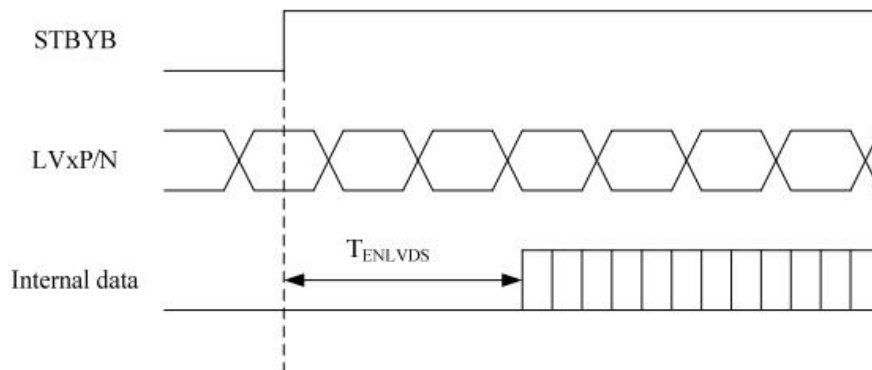

Figure 9-4: LVDS wake up time

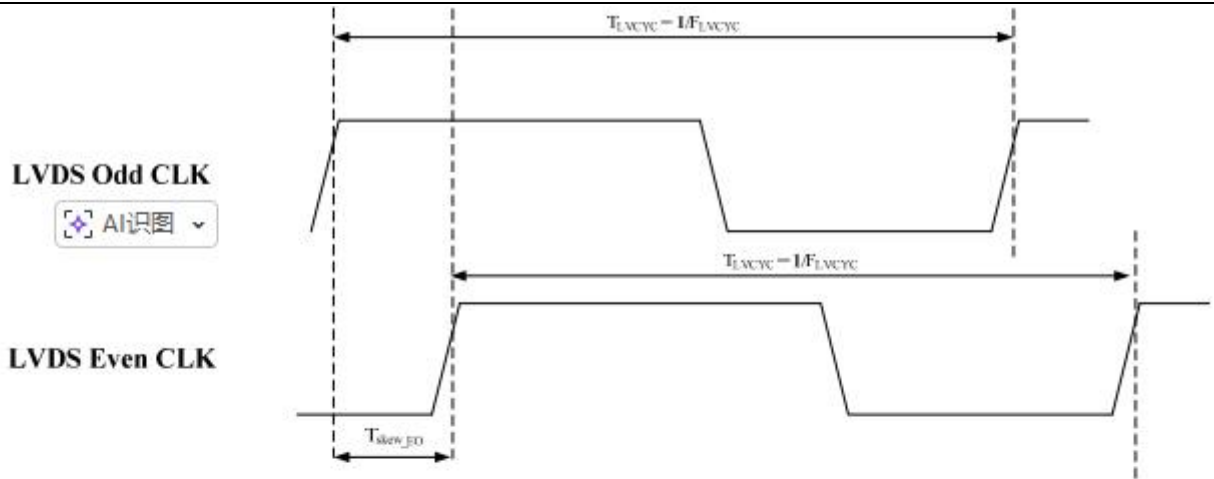

Figure 9-5: LVDS clock to clock skew

LVDS with SSC

The LVDS receiver can support spread spectrum clock (SSC). Limitation is listed as below.

Parameter	Symbol	Condition	Spec.			Unit
			Min.	Typ.	Max	
Modulation Frequency	SSC _{MF}	LVDS clock frequency center at 110MHz	-	-	200	KHz
		LVDS clock frequency center at 80MHz	-	-	200	KHz
		LVDS clock frequency center at 60MHz	-	-	150	KHz
		LVDS clock frequency center at 40MHz	-	-	100	KHz
		LVDS clock frequency center at 20MHz	-	-	100	KHz
		LVDS clock frequency center at 15MHz	-	-	100	KHz
Modulation Rate	SSC _{MR}	LVDS clock frequency + SSCMR in the range of 15MHz~105MHz	-	-	±3	%

Table 9.3: SSC limitation of LVDS interface

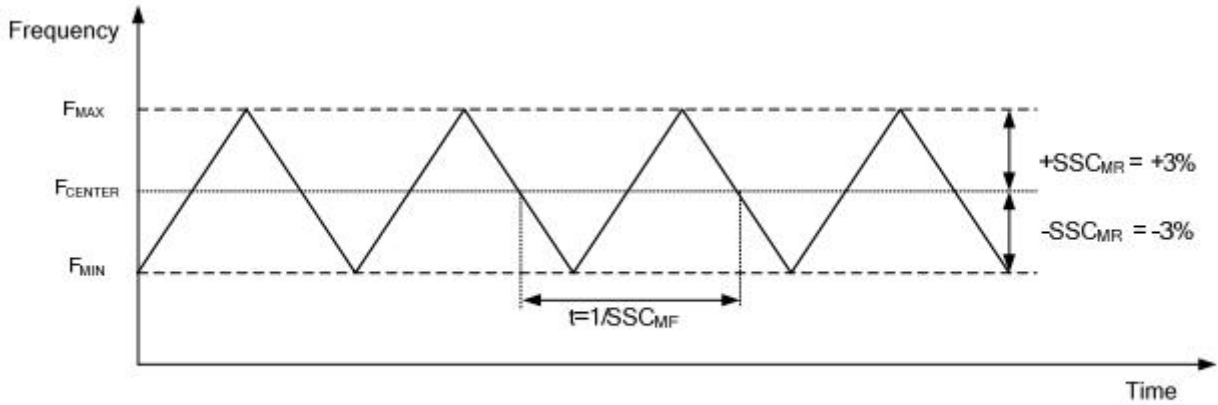

Figure 9-6: SSC figure

5.4 Reset Timing

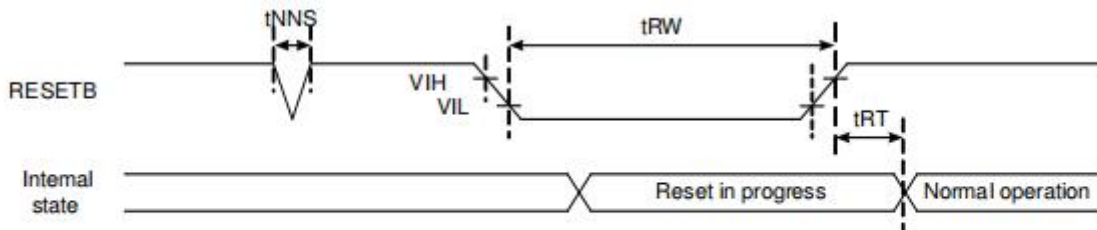

Figure 9-7: Reset timing

(VCC1=VCC1P=VCC2=VCCIF=3.0V to 3.6V, VSS1=VSS2=VSSA=0V, T_{OP}=-40~105℃)

Signal	Paramete	Symbol	Spec.			Unit
			Min.	Typ.	Max.	
RESETB	Reset pulse width	tRW	10	-	-	μs
	Reset complete time	tRT	-	-	5	μs
	Negative spike noise width	tNNS	-	-	100	ns

Table 9.4: Reset timing parameter

5.5 Display interface

8bit LVDS interface

For 1-port LVDS 8-bit mode with VESA format, only the odd port (with OLVxxx pins) is used.

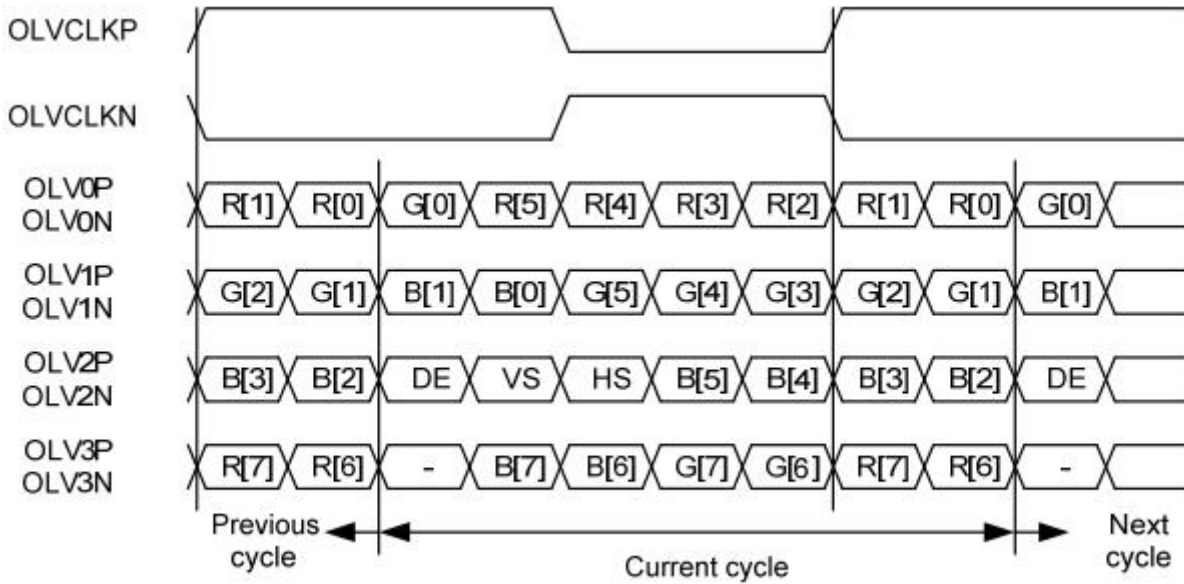

Parallel RGB with Sync mode at LVDS interface

• Horizontal

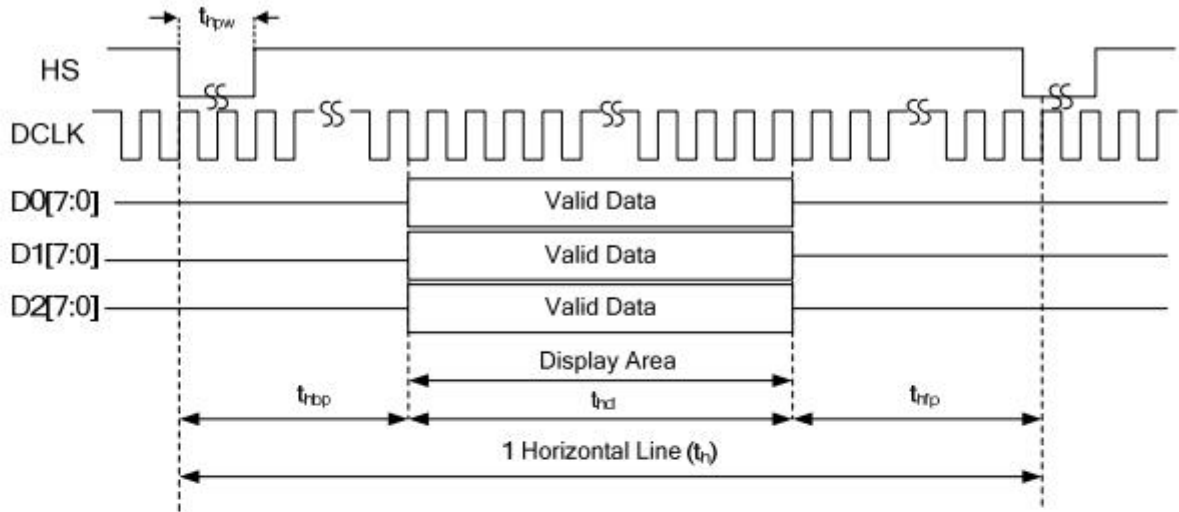

Figure 6-8: Horizontal input timing at Sync mode

• Vertical

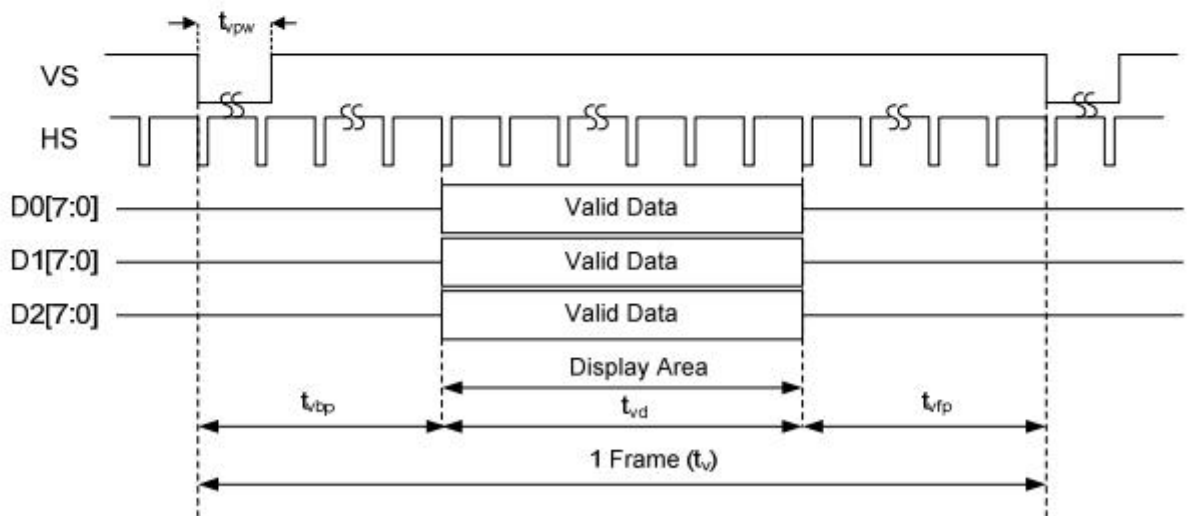

Figure 6-9: Vertical input timing at Sync mode

Parameter	Symbol	Panel Resolution									Unit
		2560xRGBx960 (Two Port)			1920xRGBx1080 (Two Port)			1920xRGBx720 (One Port)			
		Min.	Typ.	Max.	Min.	Typ.	Max.	Min.	Typ.	Max.	
DCLK frequency	F _{DCLK}		78.82			67.47			87.7		MHz
Horizontal valid data	t _{hd}	1280			960			1920			DCLK
Hsync pulse width	t _{hpw}	10	12		10	12		10	12		DCLK
Hsync back porch	t _{hbp}	5	16		5	16		5	16		DCLK
Hsync front porch	t _{hfp}	50	50		50	50		50	50		DCLK
1 horizontal line	t _h	1335	1346	1664	1015	1026	1248	1975	1986	2496	DCLK
Vertical valid data	t _{vd}	960			1080			720			H
Vsync pulse width	t _{vpw}	1	3		1	3		1	3		H
Vsync back porch	t _{vbp}	4	8		4	8		4	8		H
Vsync front porch	t _{vfp}	6	8		6	8		6	8		H
1 vertical field	t _v	970	976	1010	1090	1096	1134	730	736	756	H
Frame rate	FR	60						60			Hz

6. Optical Specifications

Item	Symbol	Condition	Min.	Typ.	Max.	Unit	Note
Viewing Angle (CR≥10) B/L ON	θ_T	$\Phi=90^\circ$ (12 o'clock)	80	85	-	deg	Note2
	θ_B	$\Phi=270^\circ$ (6 o'clock)	80	85	-	deg	Note2
	θ_L	$\Phi=180^\circ$ (9 o'clock)	80	85	-	deg	Note2
	θ_R	$\Phi=0^\circ$ (3 o'clock)	80	85	-	deg	Note2
Response Time	T_{ON}	Normal $\theta=\Phi=0^\circ$	-	-	12	msec	Note4
	T_{OFF}		-	-	12	msec	Note4
Contrast Ratio	CR		1000	1200	-	-	Note1 Note3
Color Chromaticity	W_X		0.2682	0.2982	0.3282	-	Note1 Note5
	W_Y		0.2931	0.3231	0.3531	-	Note1 Note5
Luminance	L		850	950	-	cd/m ²	Note1 Note7
Luminance Uniformity	Y_U		70	80	-	%	Note1 Note6
NTSC	-		65	70	-	%	-

Note 1: Definition of optical measurement system

The optical characteristics should be measured in dark room. After 5 minutes operation, the optical properties are measured at the center point of the LCD screen. All input terminals LCD panel must be ground when measuring the center area of the panel.

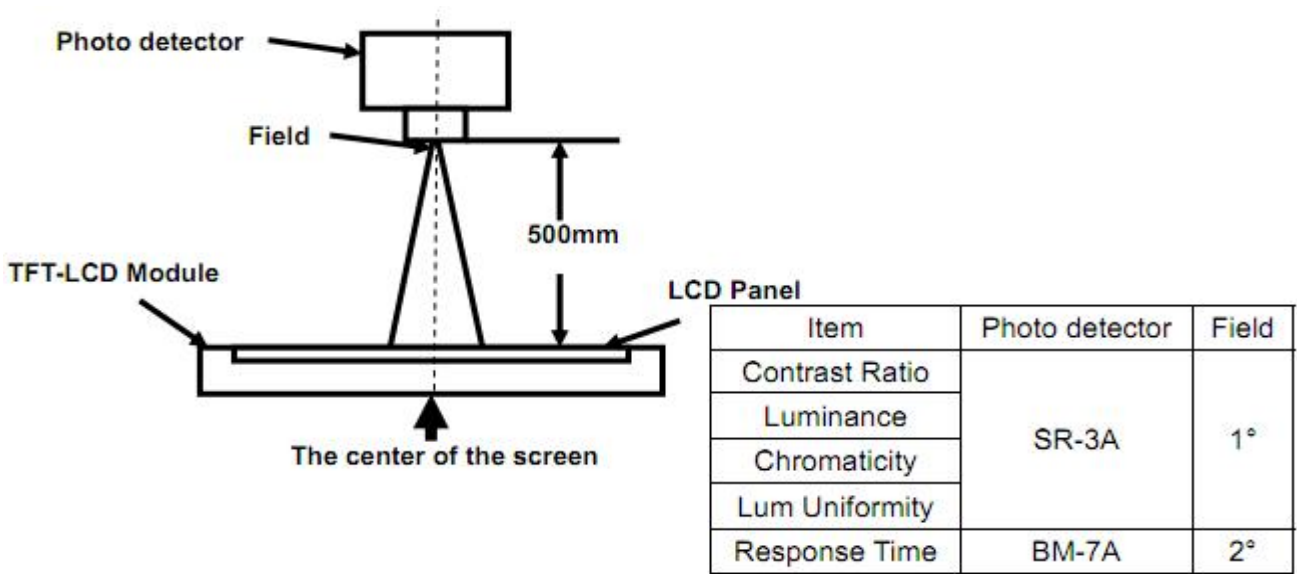

Fig 1

Note 2: Definition of viewing angle range and measurement system.

viewing angle is measured at the center point of the LCD by CONOSCOPE(ergo-80).

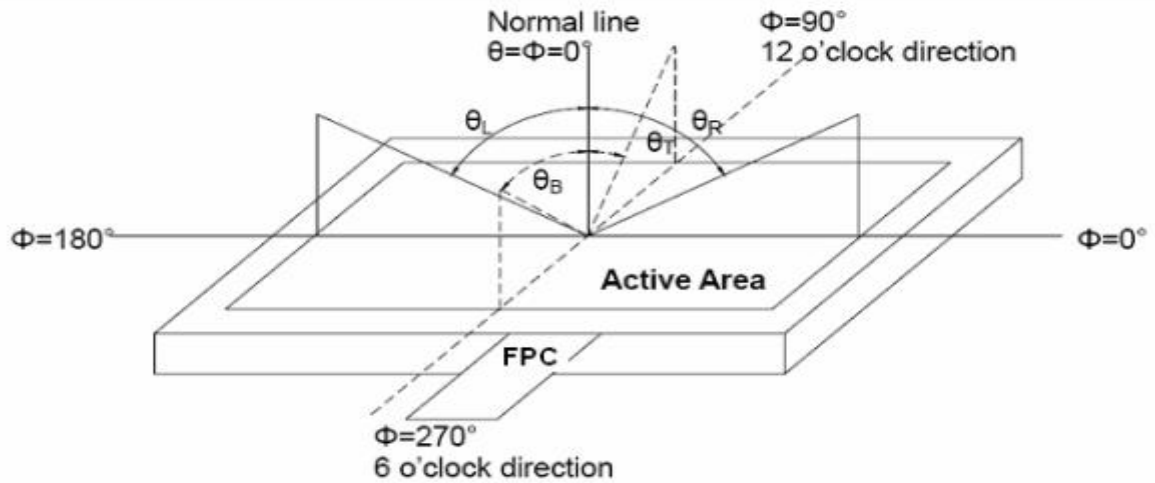

Fig 2 Definition of viewing angle

Note 3: Definition of contrast ratio

$$CR = \frac{\text{Luminance with all pixels white}}{\text{Luminance with all pixels black}}$$

Note 4: Definition of Response time

The response time is defined as the LCD optical switching time interval between “White” state and “Black” state. Rise time (TON) is the time between photo detector output intensity changed from 90% to 10%. And fall time (TOFF) is the time between photo detector output intensity changed from 10% to 90%.

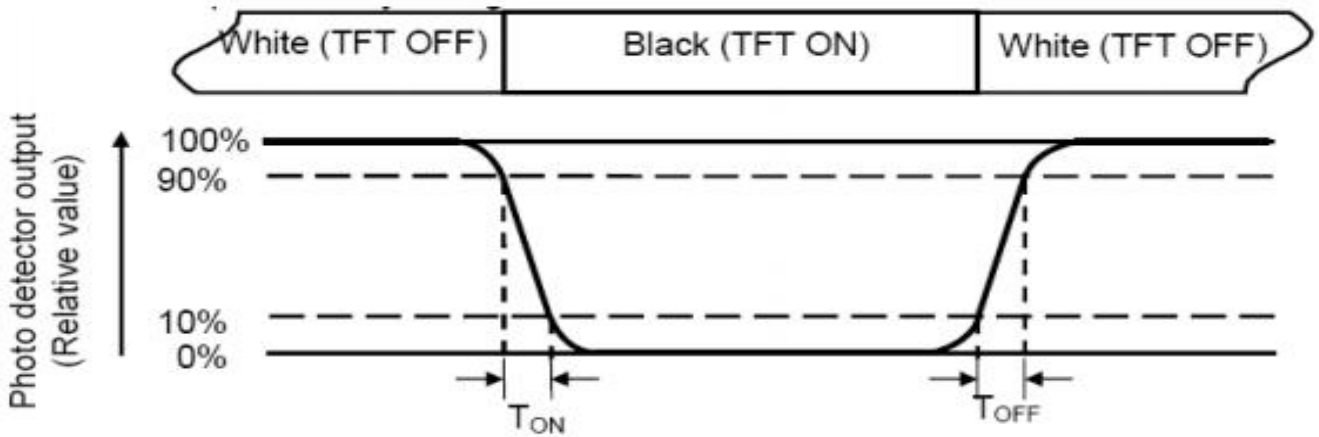

Note 5: Definition of color chromaticity (CIE1931)
Color coordinates measured at center point of LCD.

Note 6: Definition of Luminance Uniformity

The luminance uniformity in surface luminance is determined by measuring luminance at each test position 1 through n, and then dividing the maximum luminance of n points luminance by minimum luminance of n points luminance. For more information see FIG.3-a/b

Note 7: Surface luminance is the luminance with all pixels displaying white.

$$L_v = \text{Average Surface Luminance with all white pixels}(P_1, P_2, P_3, \dots, P_n)$$

For more information see FIG.3-a/b

Note 8:

H,V : Active area(see Figure b)

Light spot size $\varnothing = 5\text{mm}$ (BM-5) or $\varnothing = 7.7\text{mm}$ (BM-7)50cm distance or compatible distance from the LCD surface to detector lens. test spot position : see Figure b.

measurement instrument : TOPCON's luminance meter SR-3A or BM-7 or compatible (see Figure 1).

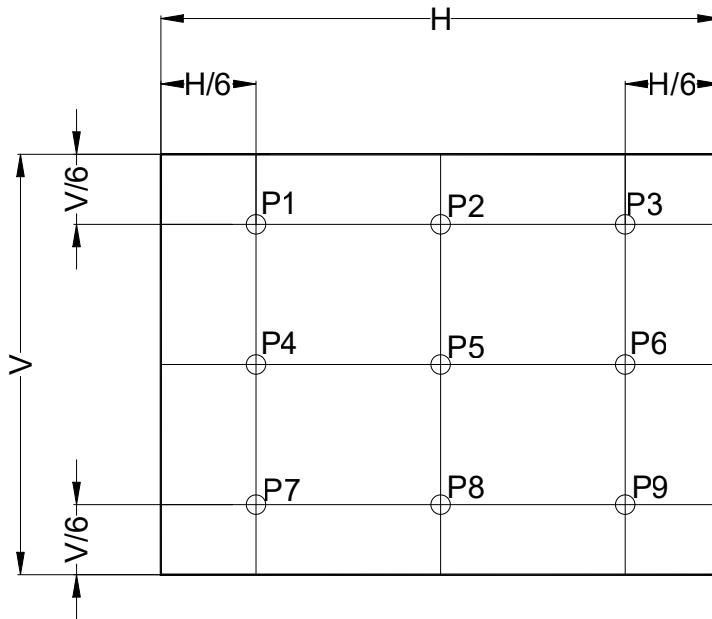

Fig. 3-b Definition of points

7. Reliability Test Items

Test Item	Test Conditions
High Temperature Storage	Ta= +85°C 96hrs
Low Temperature Storage	Ta= -30°C 96hrs
High Temperature Operation	Ta= +85°C 96hrs
Low Temperature Operation	Ta= -30°C 96hrs
High Temperature and Humidity Storage	Ta= +60°C, 90% RH 96hrs
Thermal Shock (Non-operation)	-30°C/30 min ~ +85°C/30 min for 20 cycles Start with cold temperature end with high temperature
Electro Static Discharge	Contact = ± 4 kV, class B Air = ± 8 kV, class B R=330Ω,C=150pF
Vibration	Sweep: 10Hz~55Hz~10Hz Stroke: 1.5mm 2 hrs for each direction of X .Y. Z.
Mechanical Shock	60G 6ms,±X,±Y,±Z 3 times for each direction
Package Drop Test	Height: 60 cm 1 corner, 3 edges, 6 surfaces

Notes: The test result shall be evaluated after the sample has been left at room temperature and humidity for 2 hours without load. No condensation shall be accepted. The sample will not be accepted if appear these defects:

- 1). Air bubble in the LCD
- 2). Seal leak or Glass crack
- 3). Non display or abnormal display
- 4). Brightness reduction >50%

9. Packing

Packing Method

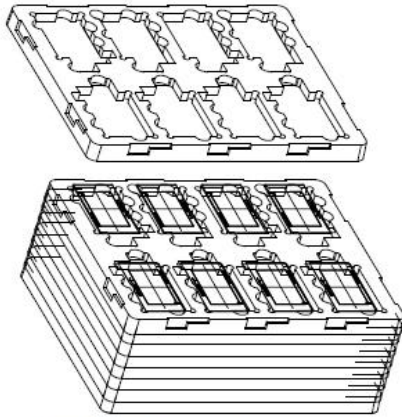

1. Put LCD module into tray cavity

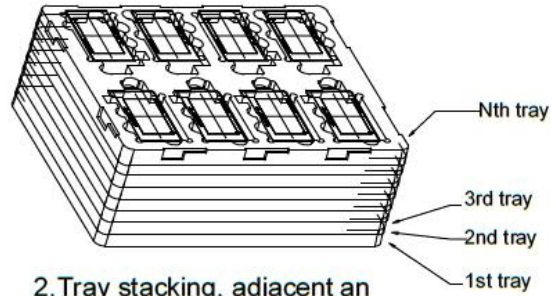

2. Tray stacking, adjacent an upper lower layer with a 180-degree rotation

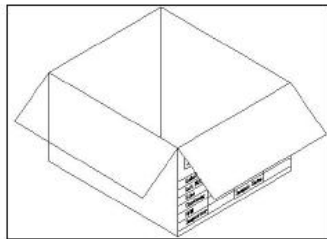

4. put the tray stack into carton

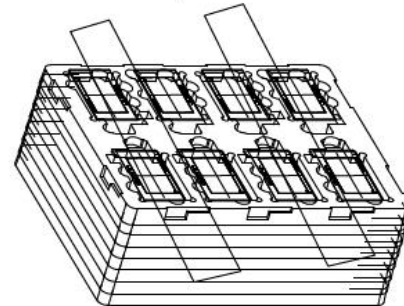

3. Medium Carton: Fix the tray stack with stretch film
Large Carton: Fix the tray stack with stretch film, then place it into a transparent PE antistatic bag

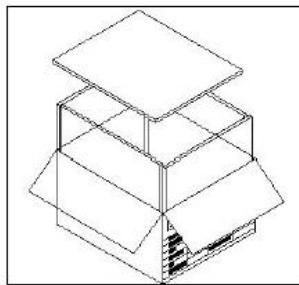

5. 6 sides of white foams inside the box

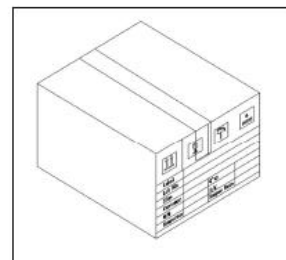

6. Carton sealing with adhesive tape

10. Precautions for Use of LCD modules

10.1 Handling Precautions

10.1.1. The display panel is made of glass. Do not subject it to a mechanical shock by dropping it from a high place, etc.

10.1.2. If the display panel is damaged and the liquid crystal substance inside it leaks out, be sure not to get any in your mouth, if the substance comes into contact with your skin or clothes, promptly wash it off using soap and water.

10.1.3. Do not apply excessive force to the display surface or the adjoining areas since this may cause the color tone to vary.

10.1.4. The polarizer covering the display surface of the LCD module is soft and easily scratched. Handle this polarizer carefully.

10.1.5. If the display surface is contaminated, breathe on the surface and gently wipe it with a soft dry cloth. If still not completely clear, moisten cloth with one of the following solvents:

- Isopropyl alcohol
- Ethyl alcohol

Solvents other than those mentioned above may damage the polarizer. Especially, do not use the following:

- Water
- Ketene
- Aromatic solvents

10.1.6. Do not attempt to disassemble the LCD Module.

10.1.7. If the logic circuit power is off, do not apply the input signals.

10.1.8. To prevent destruction of the elements by static electricity, be careful to maintain an optimum work environment.

10.1.8.1. Be sure to ground the body when handling the LCD Modules.

10.1.8.2. Tools required for assembly, such as soldering irons, must be properly ground.

10.1.8.3. To reduce the amount of static electricity generated, do not conduct assembly and other work under dry conditions.

10.1.8.4. The LCD Module is coated with a film to protect the display surface. Be care when peeling off this protective film since static electricity may be generated.

10.2 Storage Precautions

10.2.1. When storing the LCD modules, avoid exposure to direct sunlight or to the light of fluorescent lamps.

10.2.2. The LCD modules should be stored under the storage temperature range if the LCD modules will be stored for a long time, the recommend condition is :

Temperature : 0°C ~40°C Relatively humidity: ≤80%

10.2.3. The LCD modules should be stored in the room without acid, alkali and harmful gas.

10.3 Transportation Precautions

The LCD modules should be no falling and violent shocking during transportation, and also should avoid excessive press, water, damp and sunshine.

10.4 Packaging instructions

When the customers using trays, they have to stack the adjacent trays in a 180° staggered to prevent pressure that could cause product damage.